

GroundTrac[®]

The Original "Top-Down" PV Mounting System for Ground Applications

Benefits of GroundTrac[®] Patent#6,360,491

- Industry's preferred low cost and easiest to install ground mount system
 - Used for kW to Multi-MW projects
- Patented ground mount system ships from available stock
- Proprietary Drop-N-Lock rail insert drops in and locks ProSolar GroundTrac[®] rails in place
- Over 10 years of ProSolar's proven design
- Pre-engineered and tested for easy permitting
- No cross-bracing required



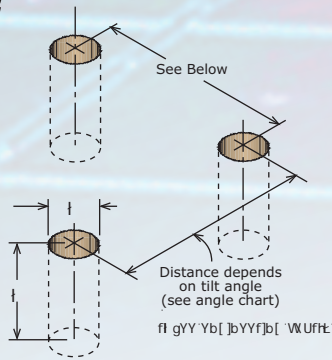
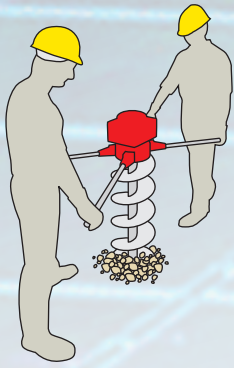

1 Dig footings. Lateral (left to right) footing spans listed on page 4 (bottom). Front to rear footing spans listed in angle charts on page 4 (top). Refer to engineering reports for footing specs.

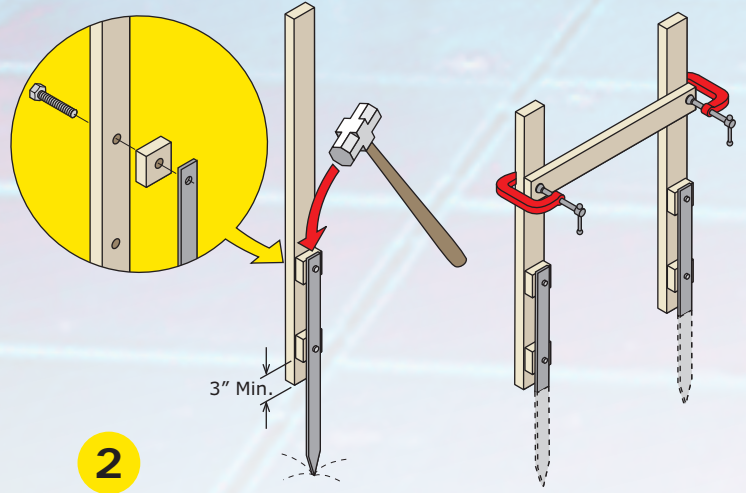

2

Assemble re-usable grade stakes (ProSolar metal grade stake kit shown). Recommend 2"x 4" vertical support. Use 1/2" drill bit and 9/16" socket to attach grade stake kit to 2" x 4". Attach 1" x 4" wooden horizontal support using 3-1/2" (min.) C-clamps. Grade stake kit includes: 24" threaded metal stake, aluminum spacer block, bolt and washer.

3 Place horizontal 1-1/2" schedule 40 galvanized water pipe with slip-on Hollaender® Tees. Adjust C-clamps as necessary to level pipe.

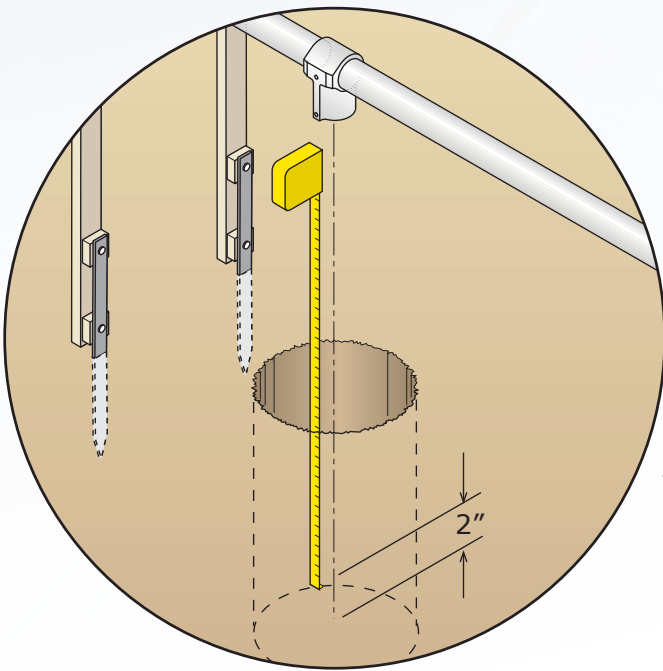
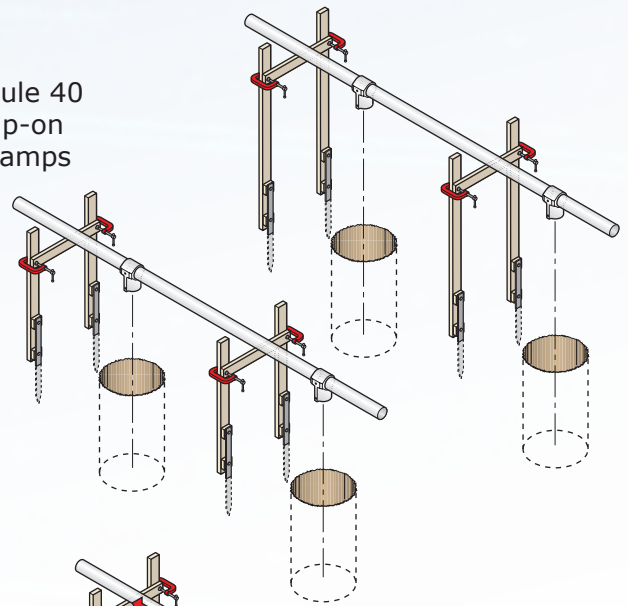

4 Measure vertical pipe lengths, allowing 2" (min.) from bottom of footing to avoid pipe contact with moisture.

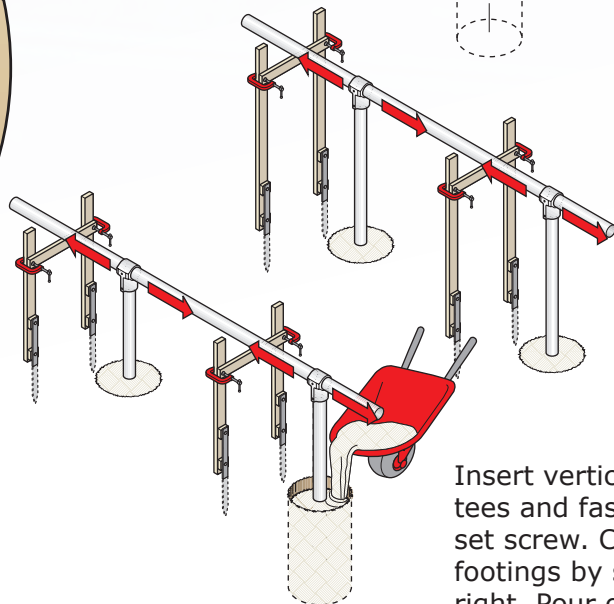

5

Insert vertical pipes into tees and fasten lower tee set screw. Center pipes in footings by sliding left or right. Pour or pump mixed concrete into footings.

Rest rail on top of horizontal pipes. Run string level on top or bottom to align tops of support rails. Fasten rail in place by using GroundTrac® drill guide along top and bottom of horizontal pipes. Drill U-bolt locking holes in place. Leave at least one drill guide attached after drilling to keep rail in place.

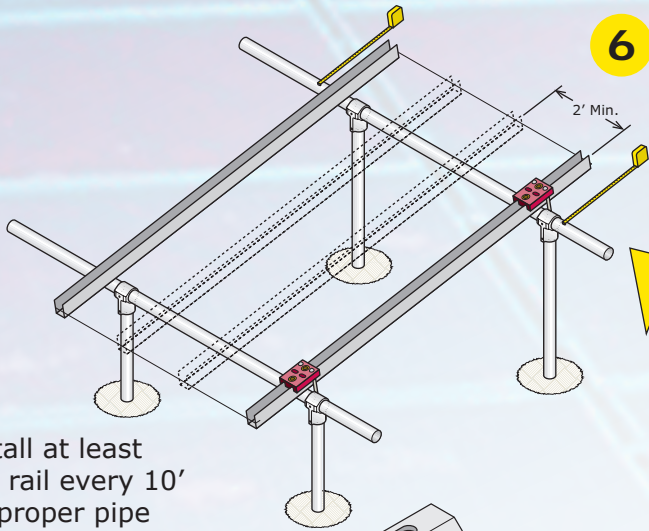

Install at least one rail every 10' for proper pipe spacing.

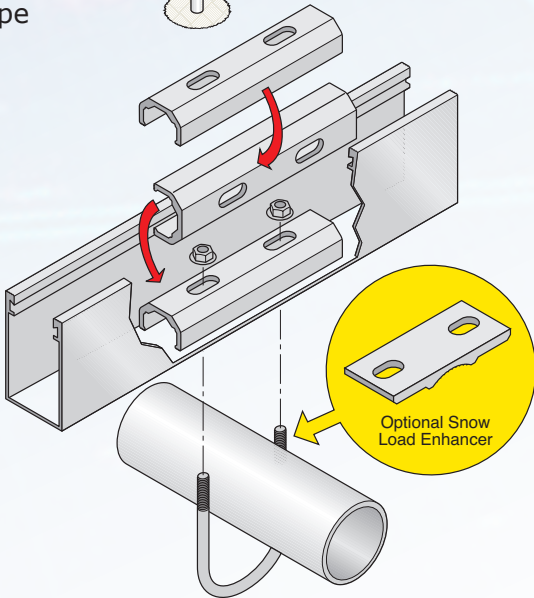

GroundTrac® Drill Guide Base and Drill Bit.

Insert U-bolt into locking rail holes and place Drop-N-Lock insert into the rail. Remove remaining drill guide and proceed with other rails.

8 Remove grade stakes. Tighten all tee set screws to 17 ft-lbs with torque wrench. Install remaining rails, evenly tightening U-bolt nuts.

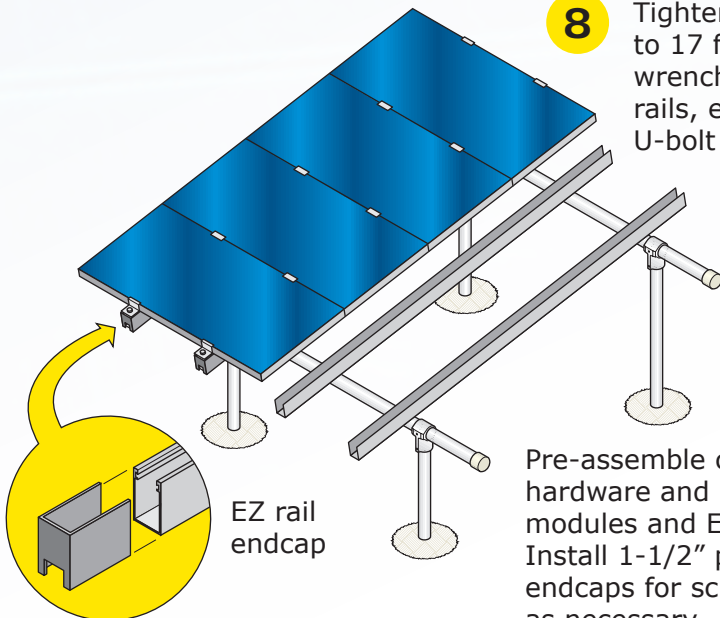

EZ rail endcap

Pre-assemble clamping hardware and install solar modules and EZ rail endcaps. Install 1-1/2" plastic pipe endcaps for schedule 40 pipe as necessary.

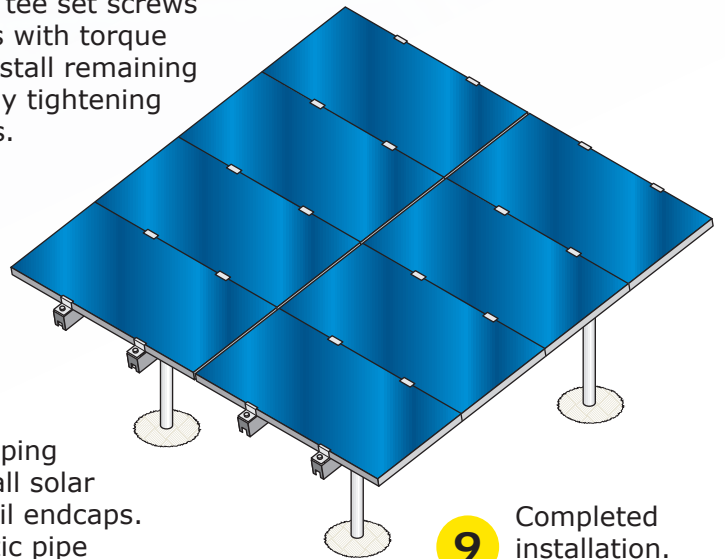

Completed installation.

124" x 2-1/2" Support Rail
Supports up to (3) 39.5" Wide Modules

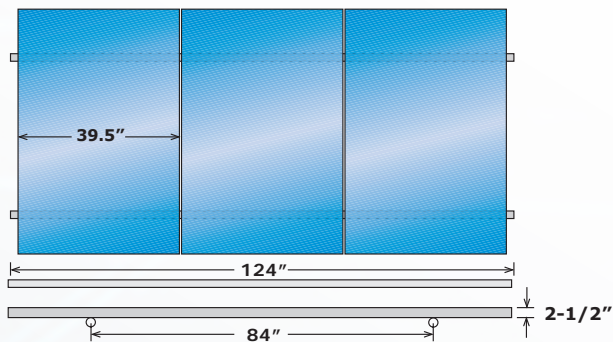

136" x 2-1/2" Support Rail
Supports up to (4) 32.5" Wide Modules

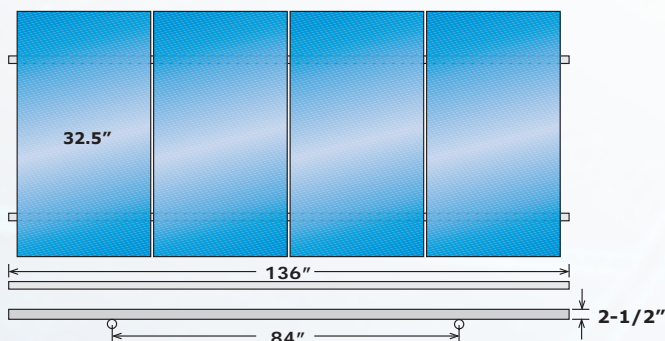

164" x 3" Support Rail
Supports up to (4) 39.5" Wide Modules

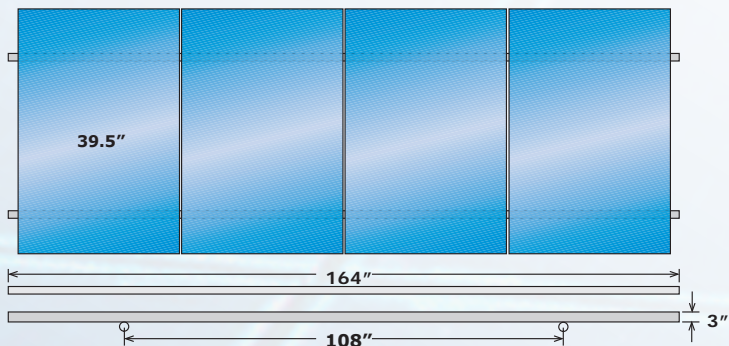

Array Angle	Front to Rear Footing Distance
0°	84"
5°	84"
10°	83"
15°	81"
20°	79"
25°	76"
30°	73"

124" and 136" Rail Angle Chart

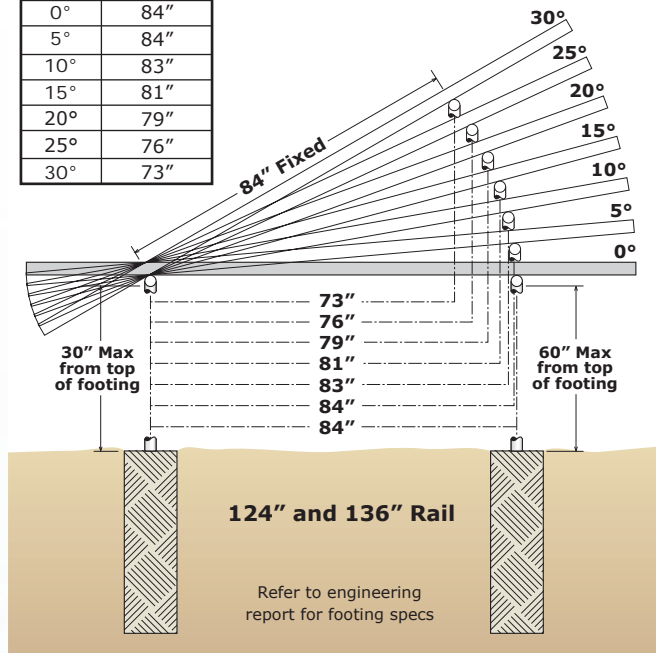

Array Angle	Front to Rear Footing Distance
0°	108"
5°	108"
10°	106"
15°	104"
20°	101"

164" Rail Angle Chart

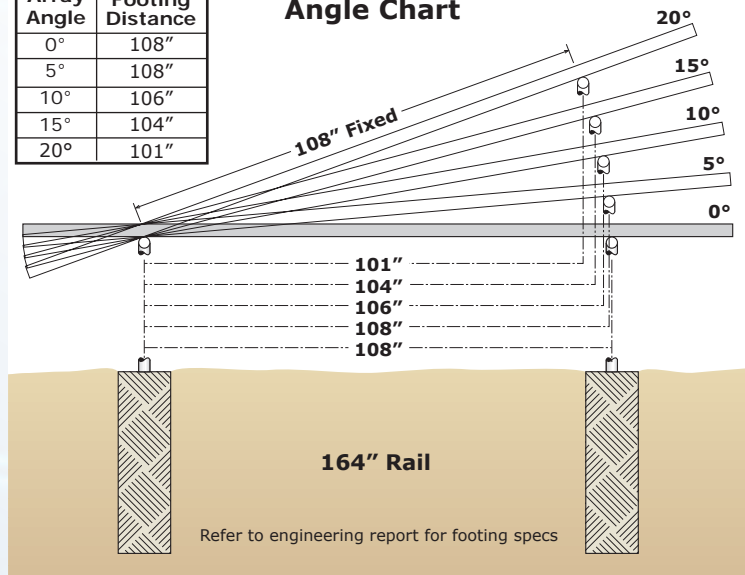

GroundTrac® Rail Sizes	124" x 2-1/2"	136" x 2-1/2"	164" x 3"
Number of Modules	(3) 39.5" wide modules	(4) 32.5" wide modules	(4) 39.5" wide modules
Lateral (left to right) footing span (max) non-snow load	10'	10'	8'
Lateral (left to right) footing span (max) 30 lb/ft ² snowload	6'	6'	Not snowload rated
Front to back footing spacing	See Angle Chart	See Angle Chart	See Angle Chart
Pre-slotted rails at:	84" on Center	84" on Center	108" on Center

Photo courtesy: Accurate Air & Electric

Professional Solar Products (ProSolar) • 1551 S. Rose Ave., Oxnard, CA 93033
805-486-4700 • www.prosolar.com

©Professional Solar Products, Inc March 2011. GroundTrac® is a registered trademark and covered under pat.#6,360,491